

XBOY TW

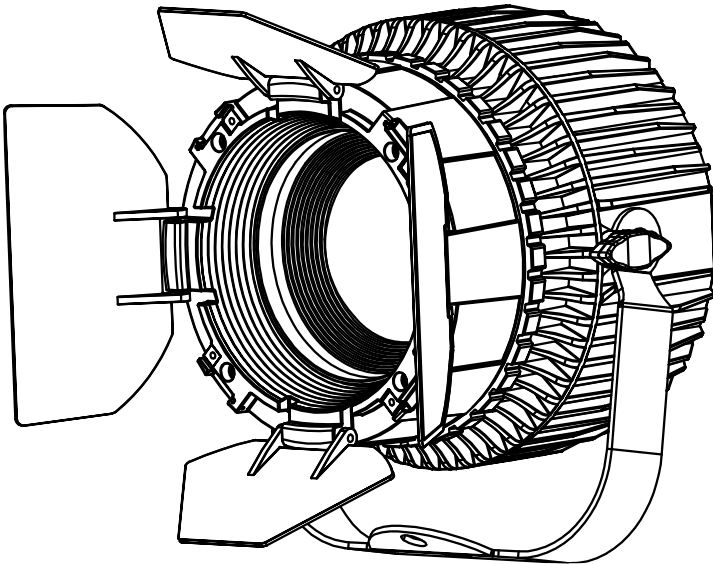

Safety Instructions:

- Do not open this device - there are no user-serviceable parts inside.
- Do not look directly at the light source when the device is on.
- Caution, this unit's housing may be hot when lights are operating.
- Do not leave any flammable material within 50 cm of this unit while operating or connected to power.
- Always use a safety cable when mounting this device overhead.
- Do not operate this device outdoors or in location where dust, excessive heat, water, or humidity may affect it.
- Do not connect this device to a dimmer or other regulated power
- Only connect this device to a grounded and protected circuit.

Main Features:

- High CRI/TLCI tunable white led-engine 2700-6500K
- Flicker free high speed PWM 16-bit dimming
- Soft condensor lens zoom optics
- Integrated rotatable barndoors
- Industry standard 5pin XLR and Neutrik True1
- Inputs and outputs for easy daisy-chaining
- RDM remote addressing
- DMX controlled rise-time
- Easy and intuitive Local menu structure.
- Firmware cloning from fixture to fixture via DMX
- Stealth design: All black parts, (body, yoke, hook clamp & bolt), Automatic dimming of LCD backlight.
- Compact size, low weight and power consumption



DMX Mode
A001 C02

Display Navigation

When XBOY TW is already in DMX-mode, the DMX start address is displayed on the left side (Axxx), while the DMX channel count is displayed on the right side (Cxx).

Use the Up/Down buttons to alter the DMX start address, and press Enter/Confirm to set the address permanently.

When receiving valid DMX, a blinking dot is displayed between the address and the channel count.



DMX Mode
A001.C02

If the XBOY TW is not in DMX-mode, or to change other settings than the start address, press the Menu button to access the main menu:



> DMX Add
DMX Cha

Manual
Mas/Sla
RF Set
Reset
Update

Menu/Exit



Enter/Confirm

Up Down

Navigate the main menu with the Up/Down buttons, and use the Enter/Confirm button to select a menu item. The XBABY TW will return to its previous state if no new setting or mode has been confirmed within 10 seconds.

DMX start Address

Use Up/Down to alter the DMX start Address (001→xxx), then press Enter/Confirm to set the chosen start address permanently. "xxx" (highest address) is determined by the chosen channel-mode. (e.g. in 2ch mode max address is 511)

- **Setting the DMX start Address will activate "DMX Mode"**



DMX Addr
<011>

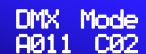

DMX Mode
A011 C02

DMX Channel count

Use Up/Down to alter the DMX channel count (1ch, 2ch, 5ch), then press Enter/Confirm to set the chosen channel count permanently.

- **Setting the DMX Channel count will activate "DMX Mode"**



DMX Chan
<02>



DMX Mode
A011 C02

Manual Control

Use Up/Down and Enter/Confirm to sequentially choose a Preset basic color-temperature, finetune the temperature of the chosen color, and finally set the overall intensity.

Use Menu/Exit to step backwards in menu-sequence to readjust the color.



- **Setting a manual color will activate “Manual Mode”**

Master/Slave Operation

Use Up/Down to choose Master or Slave, and press Enter/Confirm.

When using the Manual Control or RF remote with Master enabled, the Master fixture will transmit via the 5p XLR to control connected fixtures set to Slave Mode.

- **Setting Master/Slave to Slave will activate “Slave Mode”**



RF Setup ¹

Use Up/Down to select Off, Group1 or Group2, then press Enter/confirm to select Radio Frequency remote group.

- **Selecting RF group 1 or 2 will activate “DMX/RF” mode**



Factory Reset

Use Up/Down to select <Y> for yes, then press Enter/confirm to reset the fixture to factory default settings.

- **Resetting the fixture will activate “DMX Mode”**



Firmware Update

Use Up/Down to select <Y> for yes, then press Enter/Confirm to set the fixture in update mode.

Connect another fixture (unpowered) with 5pin, then apply power. When the second fixture displays “Waiting for file”, Press Enter/Confirm on the original fixture to start transferring firmware to the second fixture.

- **Press Menu/Exit twice to return to Main menu when done**



¹ Radiosignals are prone to interference, the RF remote is not intended for realtime/live show operation

Radio remote



DMX	Sets group 1 + 2 to DMX mode
MAN	Sets group 1 + 2 to Manual mode
OFF	Fades group 1 + 2 to Black in 3 seconds
ON	Fades group 1 + 2 back to set level in 3 seconds
D -	Decrease dimmer value of group 1 / 2 respectively
D +	Increase dimmer value of group 1 / 2 respectively
C -	Decrease color value of group 1 / 2 respectively
C +	Increase color value of group 1 / 2 respectively

To control the XBOY via Radio remote²:

1. Enable the RF receiver in the fixture by selecting either <Group1> or <Group 2> in the RF setup menu of the fixture.
2. Press MAN on the remote control to activate manual control.
3. Adjust the level and color of the chosen group via D +/- and C +/-
4. Press OFF to fade out, press ON to fade back to previous levels

² Radiosignals are prone to interference, the RF remote is not intended for realtime/live show operation. Always extend the antenna fully on the remote-control to ensure best possible transmission

DMX channels:

The XBOY TW may be set to use 1, 2, 3, or 5 DMX channels.
Please refer to the DMX Charts for detailed description of each channel

1

Dim

The 1-channel mode automatically adapts the color temperature when dimming the fixture, similar to conventional tungsten

1

Dim

2

ColorTemp

The 2-channel mode gives easy access to both intensity and color temperature from manual consoles.

1

Warm LED

2

Cool LED

3

Dim

The 3-channel mode gives raw access to each LED along with a master dimmer.

⚠ In this mode, it is possible to run both LEDs simultaneously, producing more heat than manageable over time. The fixture will soft-limit power to the LEDs when the housing is reaching maximum temperature.

1

Dim

2

Dim fine

3

ColorTemp

4

Strobe

5

Rise-time

The 5-channel mode gives individual access to color temperature, 16-bit dimmer and shutter/strobe with additional random and audio-trig, finally the rise-time channel allows for emulation of typical response-profiles found in conventional dimmer and filament lamps.

DMX Chart

1 Channel mode

CHANNEL	VALUE	FUNCTION
1	000-255	Dimmer 0% → 100%, Auto Color temperature

2 Channel mode

CHANNEL	VALUE	FUNCTION
1	000-255	Dimmer 0% → 100%
2	000-009	Auto Color temperature
	010-255	Color temperature Warm → Cool

3 Channel mode



Lumen output may be reduced due to excessive heat

CHANNEL	VALUE	FUNCTION
1	000-255	Warm White LED 0% → 100%
2	000-255	Cool White LED 0% → 100%
3	000-255	Dimmer 0% → 100%

5 Channel mode

CHANNEL	VALUE	FUNCTION
1	000-255	Master dimmer 0% → 100% (coarse)
2	000-255	Master dimmer (fine 16bit)
3	000-255	Color temperature Warm → Cool
	000-007	Shutter Closed
	008-015	Shutter Open
	016-119	Strobe Slow → Fast (1-25Hz)
4	120-127	Shutter Open
	128-183	Strobe Random Slow → Fast
	184-191	Shutter Open
	192-247	Strobe Audio Slow → Fast
	248-255	Shutter Open
	5	000-031
032-063		Short rise-time
064-095		Medium rise-time
096-127		Long rise-time
128-159		Extra-long rise-time
160-191		Tungsten Short rise-time
192-223		Tungsten Medium rise-time
224-255		Tungsten Long rise-time

Technical Specification:

Construction

Housing	Black Die-cast Aluminum Body
Cooling System	Passive fanless, Temperature protection
Power Input/Output	Neutrik Powercon True1
DMX Input/Output	5-pin XLR
Display	Blue/white Backlit LCD, auto-dimmed when idle.
Dimension (LxWxH)	167 x 200 x 218 mm
Weight	3.2kg

Electric

Power supply	100-240V AC, 50/60 Hz
Power consumption	Max 120W
LED Driver	Constant Current Driver, 25kHz (Flicker Free)
Fuse	T2A , 250V

Optics

Light Source	100+100W COB tunable white - CRI95+ 2700->6500K
Fixture Lumen	3400 lumen (52°)
Beam Angle	20-52°

Functions

Control Modes	DMX512, RF, RDM, Manual, Master/Slave
DMX Channels	1/2/3/5CH

Operation

Temperature	Max ambient temperature Ta: 40°C Max housing temperature Tc (steady state): 80°C
Distance	Min. distance from flammable surfaces: 0.5 m Min. distance to lighted object: 0.1 m

Compliance

LVD	EN60598-2-17:1989+A2:1991 EN60598-1:2008+A11:2009
EMC	EN55015:2006+A1:2007+A2:2009 EN61547:2009 EN61000-3-2:2006+A12009+A2:2009 EN61000-3-3:2008

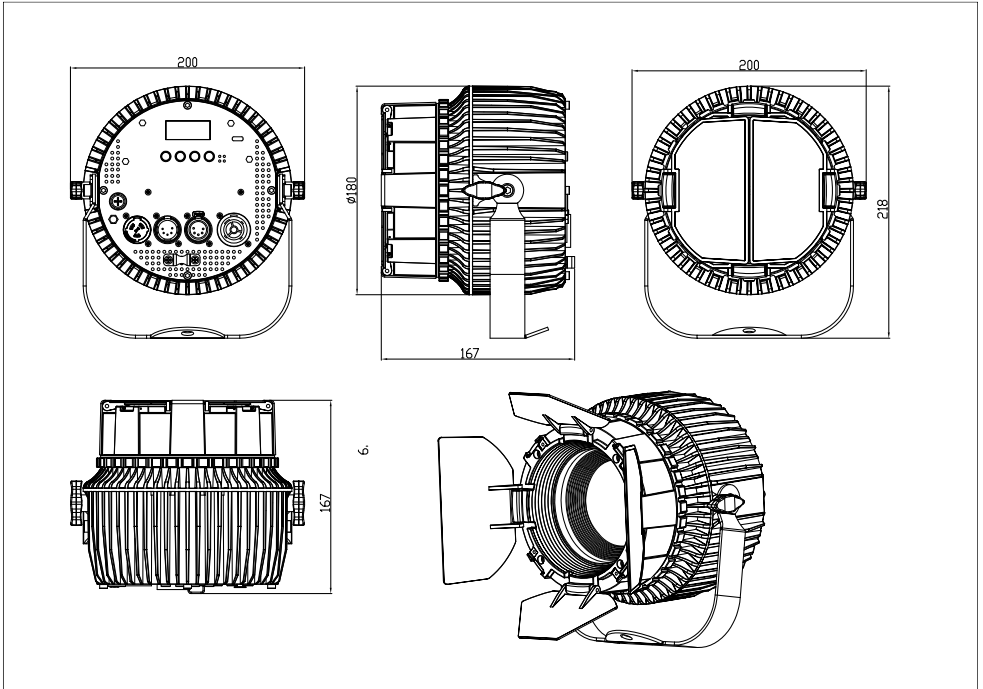

© 2025 CT Norway AS - Information subject to change without notice.
CT Norway and all affiliated companies disclaim liability for any injury,
damage, direct or indirect loss, consequential or economic loss or any other
loss occasioned by the use of, inability to use or reliance on the information
contained in this manual.

Creative Technology Norway AS • Brugata 19 • N-0186 Oslo • Norway •